



RivetKing® Long Length Rivet

ALUMINUM/ STEEL LONG LENGTH BLIND RIVETS DOME HEAD

RIVET: ALUMINUM | MANDREL: STEEL, TRIVALENT ZINC PLATED



Long length blind rivets are used in areas that require a thick grip range that goes beyond standard sizes. Used in insulation, roofing or other industrial extended grip, blind side applications.

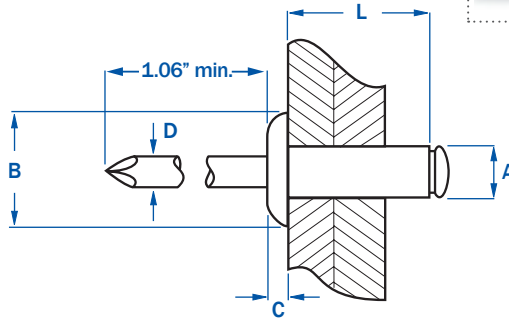

PART NUMBER	A	GRIP RANGE	L	B	C	D	HOLE SIZE	SHEAR	TENSILE
	RIVET SIZE		LENGTH	HEAD DIA	HEAD HEIGHT	MANDREL DIA			
01050004035	5/32"	1.02 - 1.25	1.38	.300	.047	.083	.161	180	220
01050004040		1.25 - 1.44	1.57						
01050005040	3/16" **	1.18 - 1.38	1.57	.366	.060	.108	.200	450	618
01050005045		1.37 - 1.58	1.77						
01050005050		1.57 - 1.77	1.97						
01050005055		1.77 - 1.98	2.17						
01050005060		1.98 - 2.17	2.37						
01050005065		2.17 - 3.26	2.57						
01050005070		2.36 - 2.56	2.77						
01050005075		2.56 - 2.75	2.95						
01050005080		2.76 - 2.95	3.15						
01050005090		2.95 - 3.35	3.54						
010500050100		3.35 - 3.74	3.93						
010500050110		3.74 - 4.13	4.33						
010500050120		1.14 - 4.53	4.72						
010500050130		4.52 - 4.92	5.12						
010500050140		4.92 - 5.32	5.52						
010500050150		5.32 - 5.71	6.29						
010500050160		5.71 - 5.91	4.77						
010500050170		6.10 - 6.50	6.70						
010500050180	6.50 - 6.89	7.09							
010500050190	6.89 - 7.29	7.50							
01050006480	1/4"	1.65 - 2.87	3.15	.512	.079	.142	2.56	550	765
010500064100		2.87 - 3.66	3.93						
010500064120		3.66 - 4.45	4.72						
010500064150		4.45 - 5.63	6.91						
010500064175		5.63 - 6.61	6.89						
010500064200		6.61 - 7.60	7.87						

3/16" **

The 3/16" rivets are made according to din7337 standard in which the body diameter is actually 5mm (.196).

The 3/16" inch designation has been applied as a reference only as the actual rivet is .196 diameter.

Please insure the hole design is greater than .200 to accommodate the rivet.