



RivetKing® Rivinox®

STAINLESS STEEL • HIGH SHEAR • REAR FLANGE RIVET

RIVET: 18-8 STAINLESS | MANDREL: 18-8 STAINLESS

The Rivinox® rivet provides for an aesthetic secondary rear flange at the back side of the application. Perfect for thin sheet metals or plastics where rivet pull through is of concern. The mandrel will break nearly flush with the head and contains a locked mandrel to prevent vibration. 18-8 stainless steel constructions provides a corrosion resistant joint.

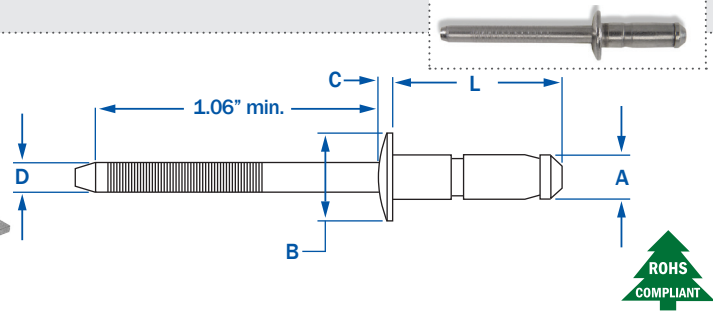
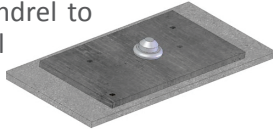

PART NUMBER	RIVET SIZE	GRIP RANGE MIN - MAX	L LENGTH NOM.	B HEAD DIA MAX.	C HEAD HEIGHT MAX.	D MANDREL DIA NOM.	HOLE SIZE MIN - MAX	SHEAR LBS.F	TENSILE LBS.F
FBF - 0408 /RIVINOX	1/8"	.040 - .118	.350	.250	.043	.082	.129 - .134	719	450
FBF - 0411 /RIVINOX		.118 - .197	.450						
FBF - 0414 /RIVINOX		.197 - .276	.540						
FBF - 0509 /RIVINOX	5/32"	.039 - .118	.400	.312	.060	.104	.161 - .169	1169	899
FBF - 0512 /RIVINOX		.118 - .197	.480						
FBF - 0516 /RIVINOX		.197 - .276	.600						
FBF - 0611 /RIVINOX	3/16"	.059 - .138	.510	.375	.070	.127	.193 - .201	1236	1124
FBF - 0614 /RIVINOX		.138 - .236	.610						
FBF - 0618 /RIVINOX		.236 - .335	.730						

SPECIAL SIZES AVAILABLE ON REQUEST



RivetKing® Rivibulb®

ALL STEEL • HIGH SHEAR • REAR FLANGE RIVET

RIVET: C-1010 STEEL, TRIVALENT ZINC CLEAR PLATED | MANDREL: HIGH CARBON STEEL, TRIVALENT ZINC PLATED

The Rivibulb® rivet provides for an aesthetic secondary rear flange at the back side of the application. Perfect for thin sheet metals or plastics where rivet pull through is of concern. The mandrel will break nearly flush with the head and contains a locked mandrel to prevent vibration. Trivalent Zinc Plated for ROHS compliance.

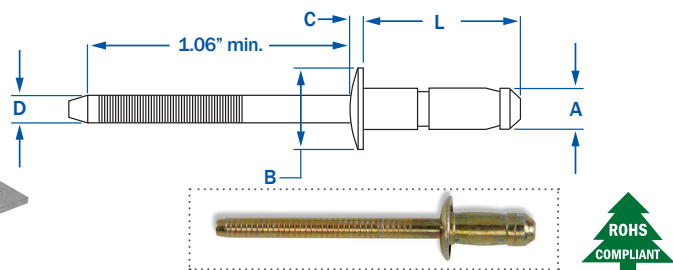
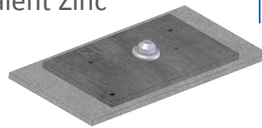

PART NUMBER	RIVET SIZE	GRIP RANGE MIN. - MAX.	L LENGTH NOM.	B HEAD DIA MAX.	C HEAD HEIGHT MAX.	D MANDREL DIA NOM.	HOLE SIZE MIN. - MAX.	SHEAR LBS.F	TENSILE LBS.F
SBS - 0408 /RVB	1/8"	.039 - .118	.360	.268	.055	.083	.129 - .134	270	292
SBS - 0411 /RVB		.118 - .197	.461					393	
SBS - 0414 /RVB		.197 - .276	.551					562	
SBS - 0509 /RVB	5/32"	.039 - .118	.410	.315	.059	.102	.161 - .169	539	629
SBS - 0512 /RVB		.118 - .197	.510					787	
SBS - 0516 /RVB		.197 - .276	.620					921	
SBS - 0611 /RVB	3/16"	.059 - .138	.480	.378	.059	.126	.193 - .201	809	855
SBS - 0614 /RVB		.138 - .236	.580					944	
SBS - 0618 /RVB		.236 - .335	.695					1258	
SBS - M6X10 /RVB	6mm	.060 - .156	.413	.472	.078	.156	.240 - .248	945	1215
SBS - M6X13 /RVB		.118 - .236	.532					1215	
SBS - M6X16 /RVB		.236 - .354	.650					1913	
SBS - M6X19 /RVB		.354 - .472	.768					1913	

SPECIAL SIZES AVAILABLE ON REQUEST